

π -Way Recap

3 atom " π -ways" we have seen

Conjugation \rightarrow " π way" \rightarrow 4 atoms or more

\rightarrow More than one π bond that overlaps

Not conjugated:

Generation of heat, Most molecules

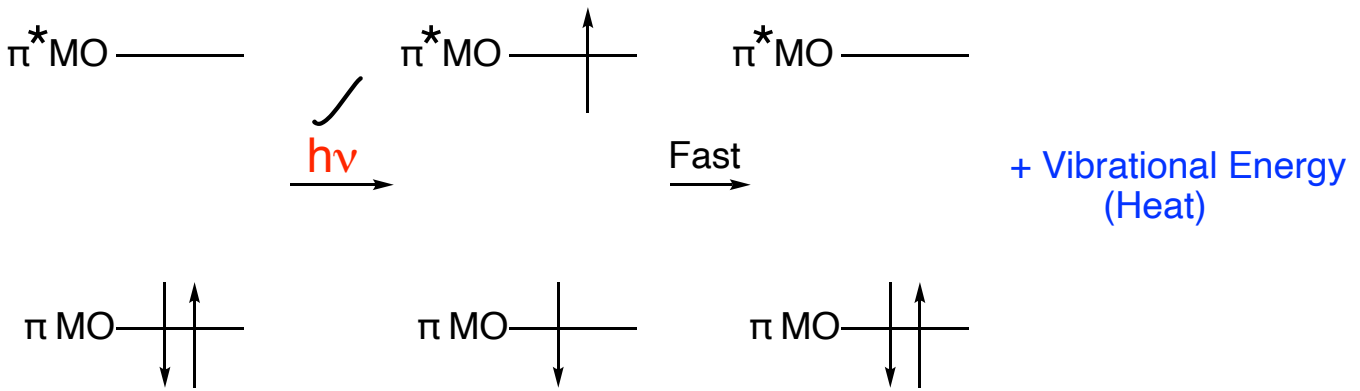

Flourescence - Rigid Molecules, Not uncommon

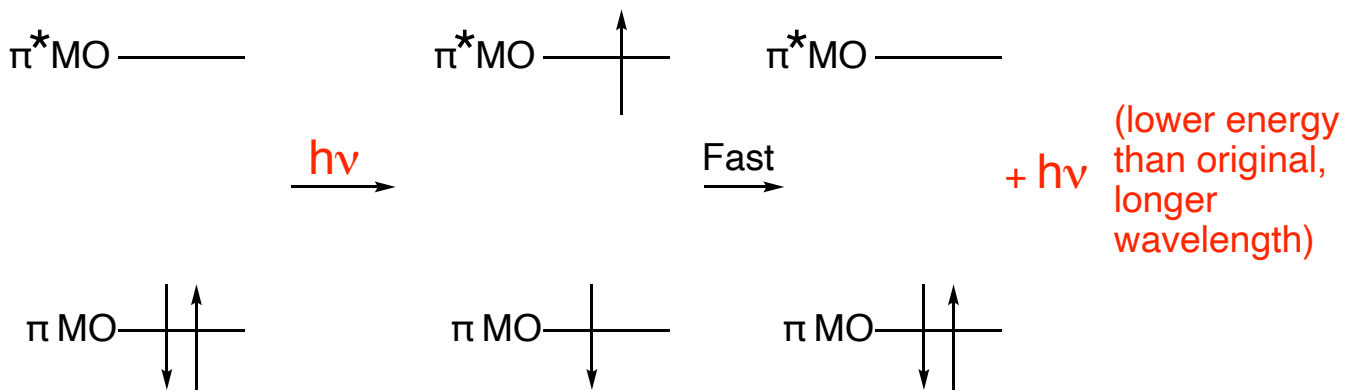

Phosphorescence - "Glow in the Dark", Rare

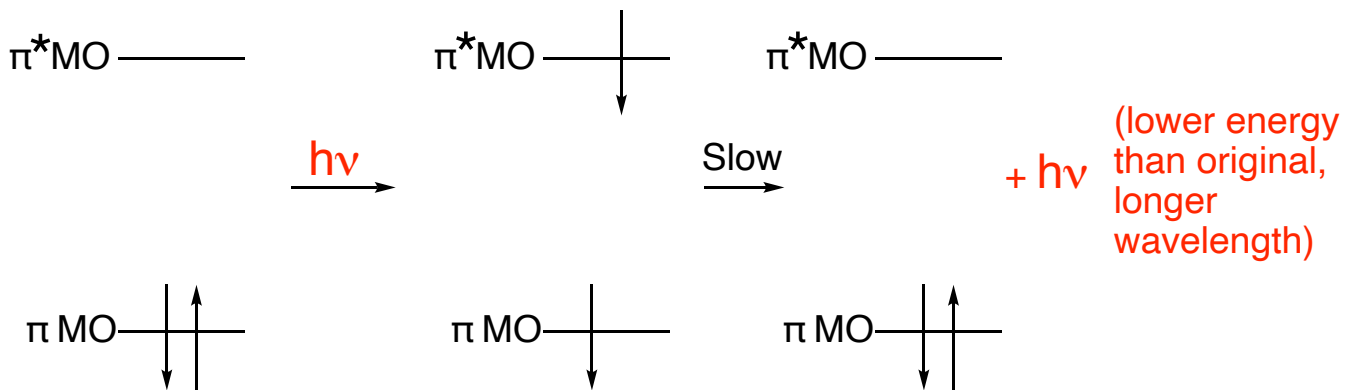

Flourescence - Rigid Molecules, Not uncommon

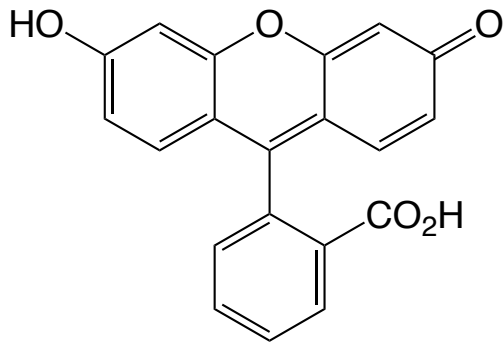

Fluorescein

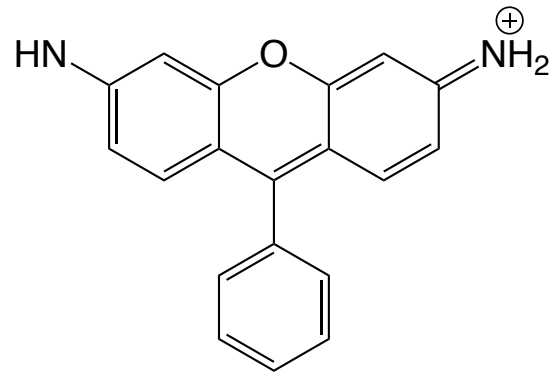

Rhodamine

Phosphorescence - "Glow in the Dark", Rare

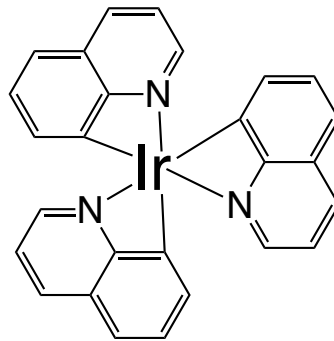

Bioluminescence - Fireflies, Deep Sea Creatures - Chemical Reactions

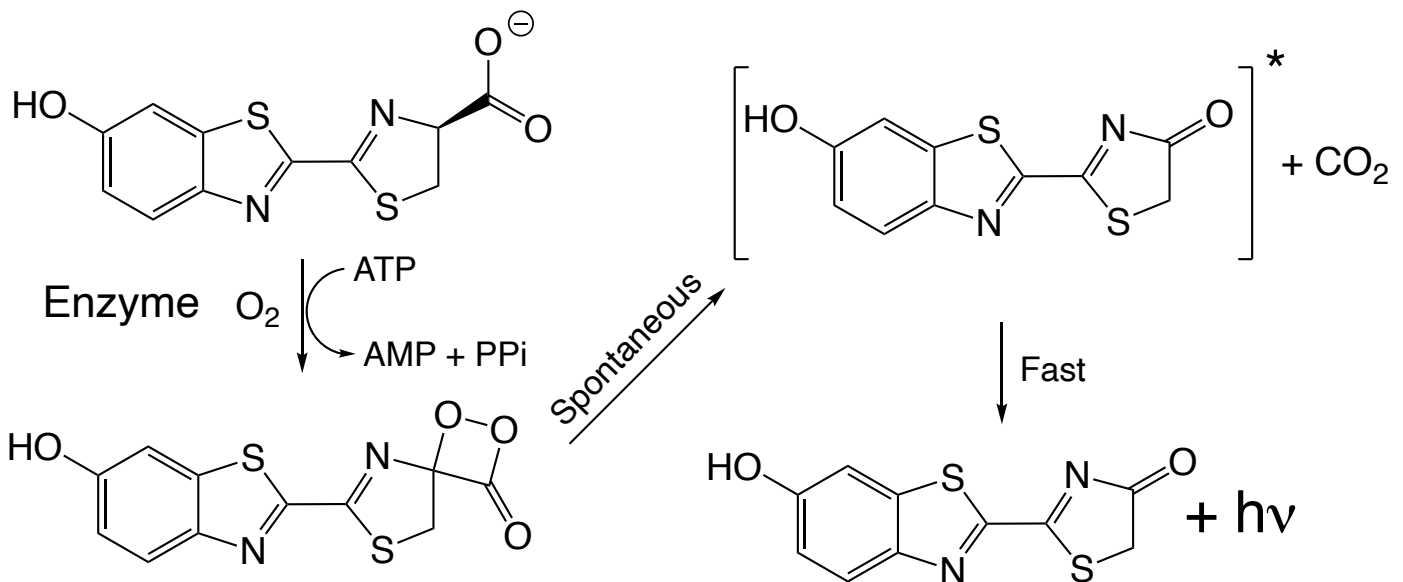

← Energy

Light source
↙ ↘

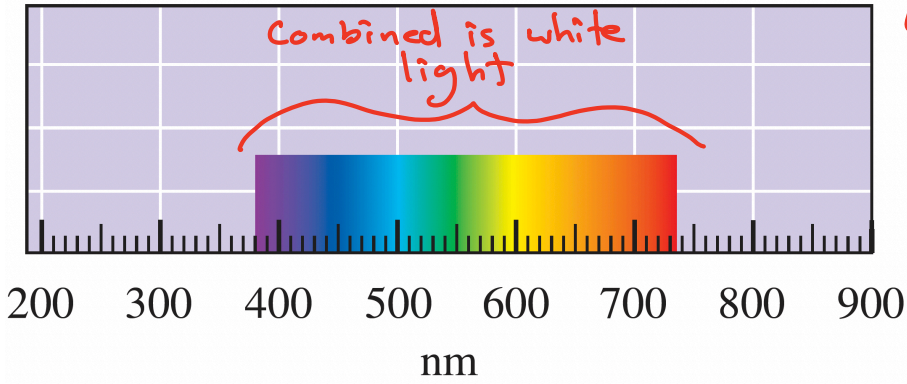
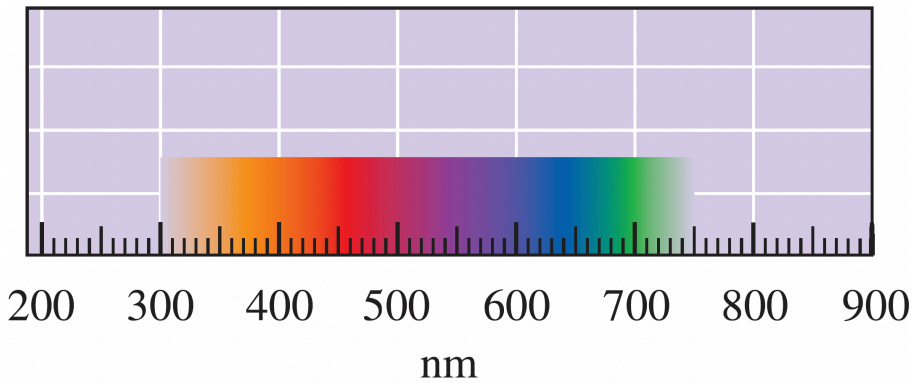
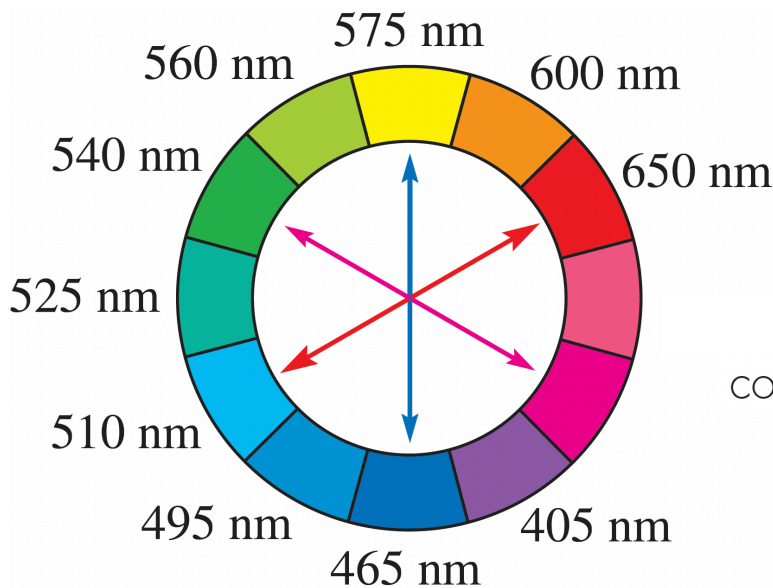

FIGURE 20.5 (a) Visible light color-wavelength correlation.

*** We "see" the wavelengths reflected minus the wavelengths absorbed ***



(b) Approximate color of substance (reflected light) if a single wavelength (i.e., the wavelength listed on the numerical scale of the x-axis) is absorbed.



(c) Complementary colors on a color wheel.

Colored arrows are complementary

Vanta Black → The "blackest" material

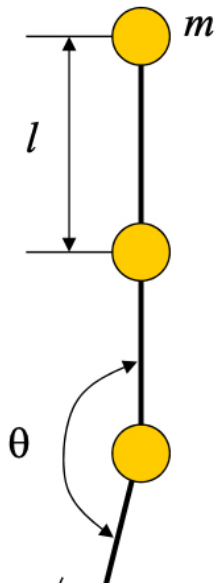
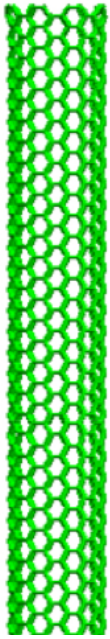

Vertically aligned CNTs

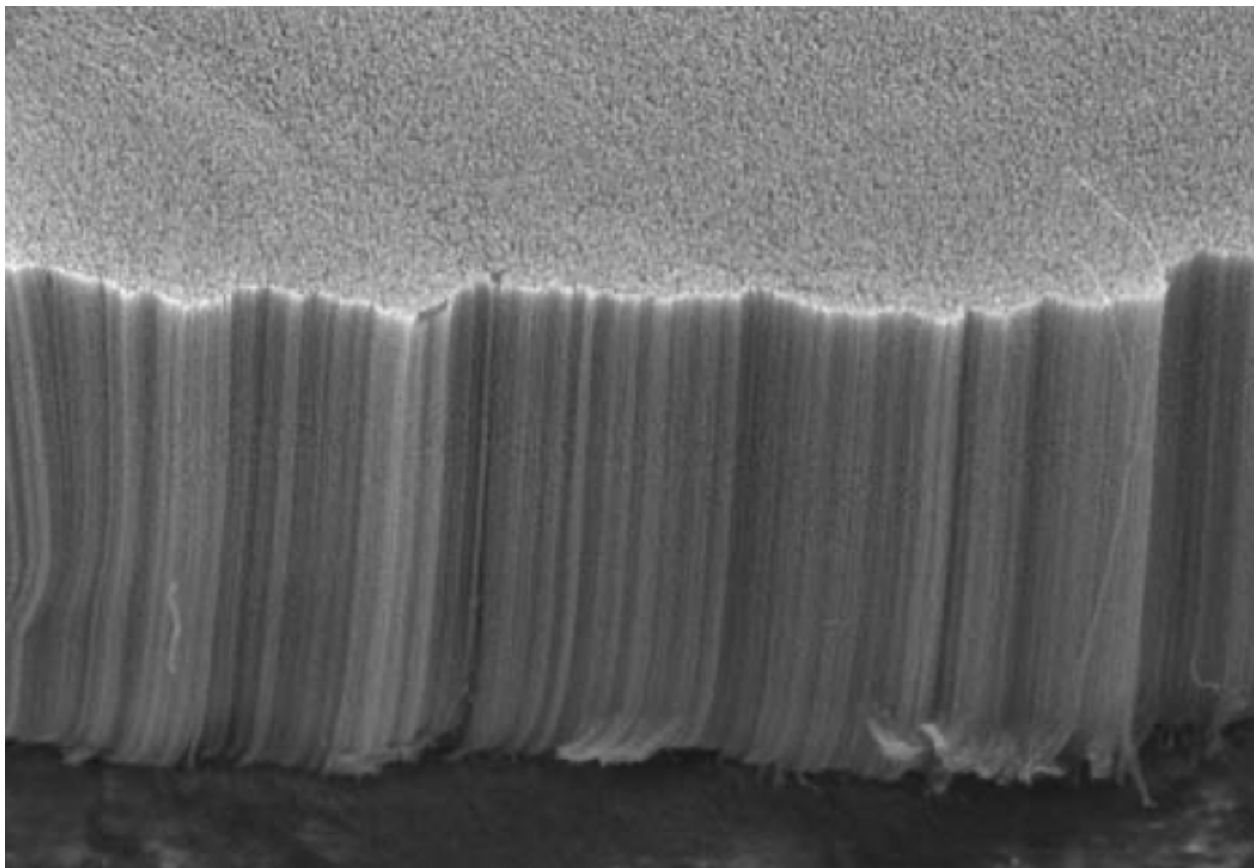
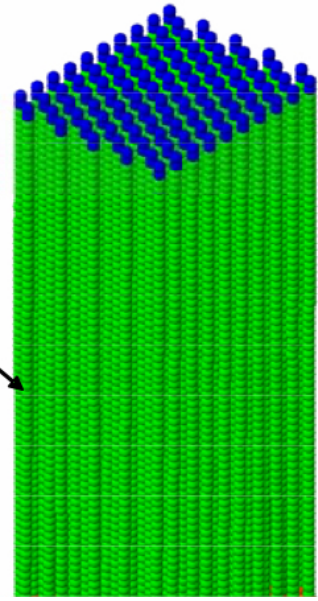

Preview

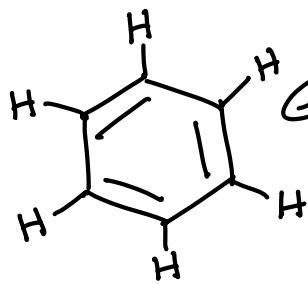

Benzene

← Extraordinarily Stable!

Pericyclic Reactions → π bonds and σ bonds interchange

Diels-Alder Reaction

..... bonds being broken

..... bonds forming

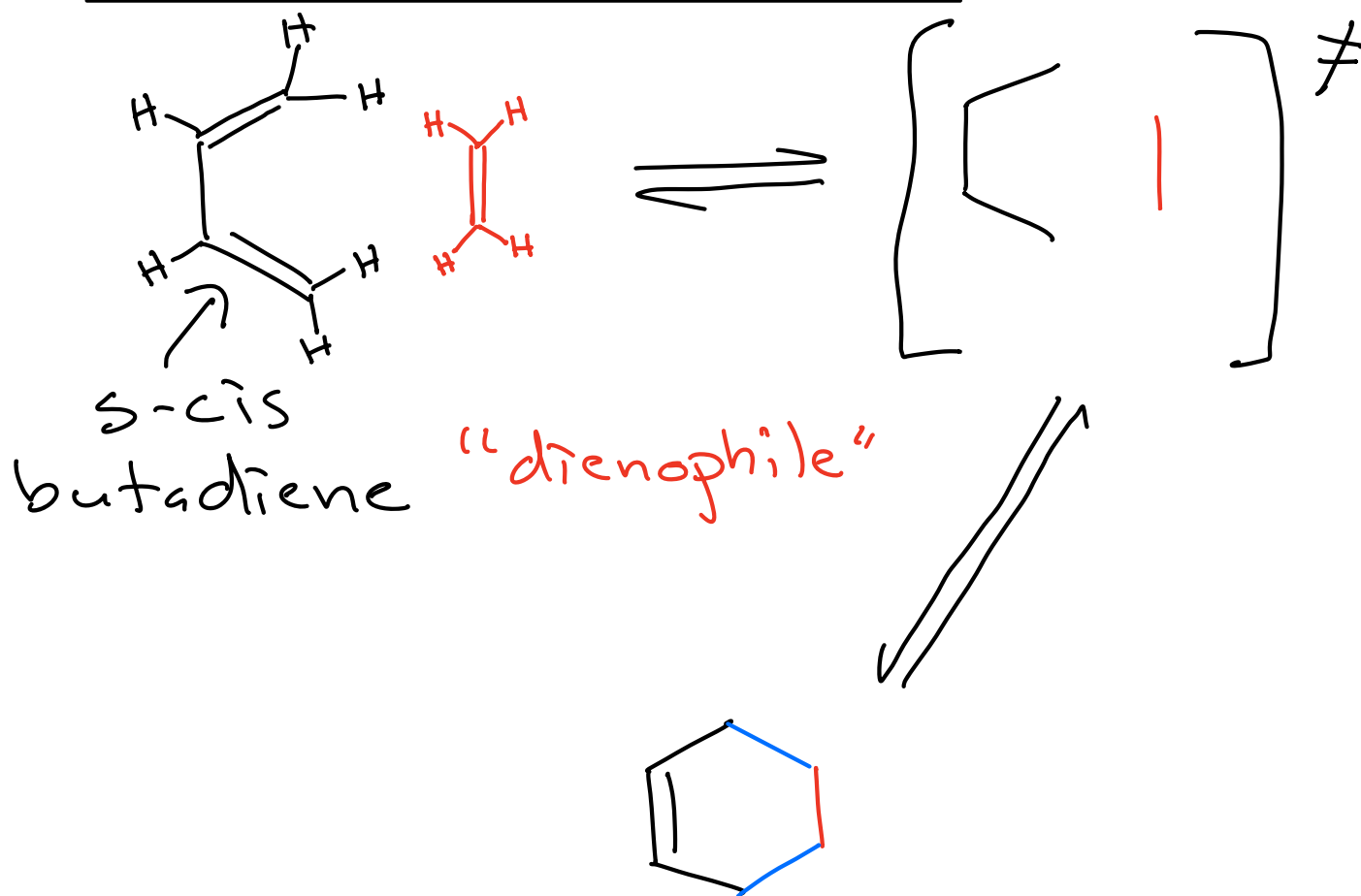

The above reaction gives a poor yield and was used only to illustrate the process → there are many, many known examples of Diels-Alder reactions

The following is the only Diels-Alder reaction you are responsible for in this class

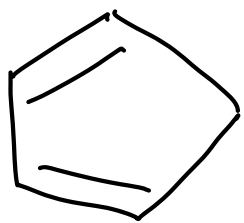

Cyclopentadiene

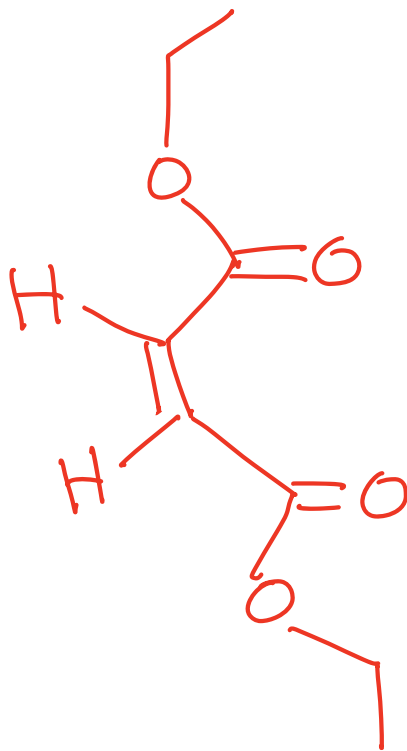

Highly reactive dienophile

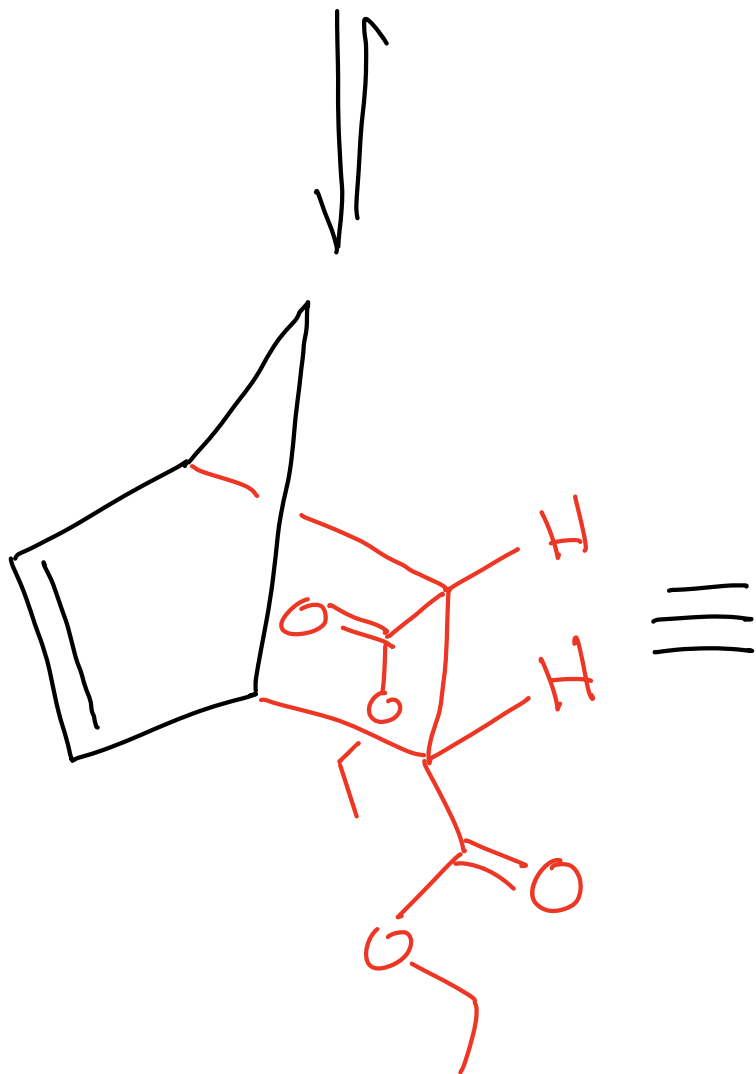

Otto!



Diels-Alder Reaction

..... bonds being broken

..... bonds forming

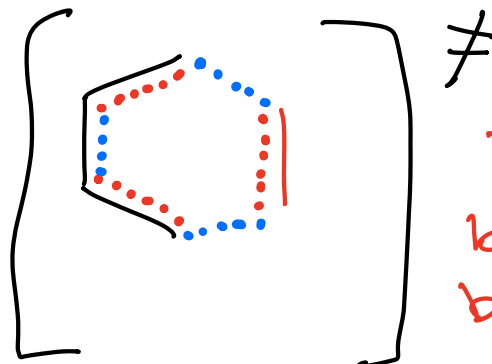
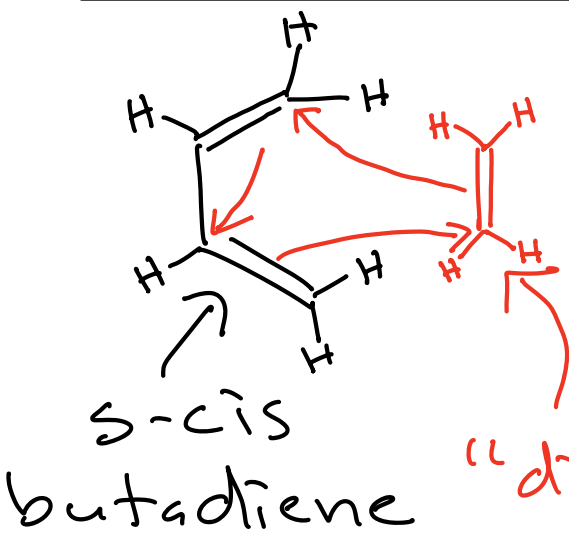

3 π bonds being made or used -

all ring atoms are sp^2 hybridized to begin with

New π bond

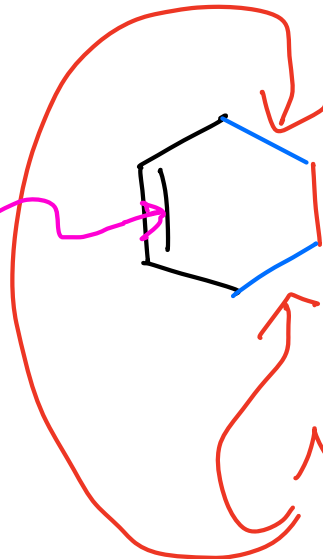

New C-C bonds!

The above reaction gives a poor yield and was used only to illustrate the process \rightarrow there are many, many known examples of Diels-Alder reactions

You have seen one other example of this type of reaction:

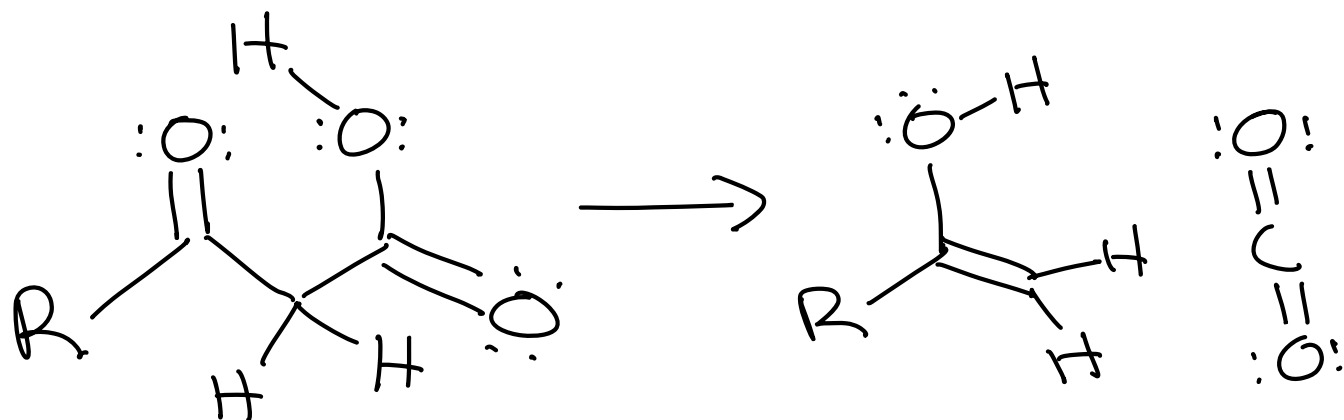

3 π bonds being broken or formed in the transition state \rightarrow very stable transition state!

The Golden Rules of Organic Chemistry

Your goal should be to understand, not memorize, the material presented in your organic chemistry course. The following principles should be learned as you begin your study of organic chemistry, then used as a solid foundation for building your understanding throughout the course. These simple ideas explain a great deal about the structures and properties of organic molecules, as well as the characteristic ways in which they react. Thoroughly understanding the following three key principles and related ideas will allow you to develop an intuitive feel for organic chemistry that avoids the necessity of resorting to the far less effective use of extensive memorization.

A. Predicting Structure and Bonding

1. In most stable molecules, all the atoms will have filled valence shells.
2. Five- and six-membered rings are the most stable.
3. There are two possible arrangements of four different groups around a tetrahedral atom.

B. Predicting Stability and Properties

4. The most important question in organic chemistry is "Where are the electrons?"
5. Delocalization of charge over a larger area is stabilizing.
6. Delocalization of unpaired electron density over a larger area is stabilizing.
7. Delocalization of pi electron density over a larger area is stabilizing.

C. Predicting Reactions

8. Reactions will occur if the products are more stable than the reactants and the energy barrier is low enough.
9. Functional groups react the same in different molecules.
10. A reaction mechanism describes the sequence of steps occurring during a reaction.
11. Most bond-making steps in reaction mechanisms involve nucleophiles reacting with electrophiles.

All conjugated systems are extra stable, but there is a certain class that is particularly stable:

Aromatic Rings

1)

2)

3)

4)

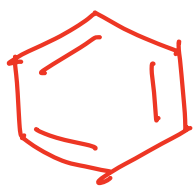

Benzene

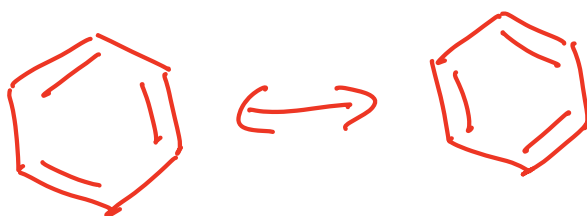

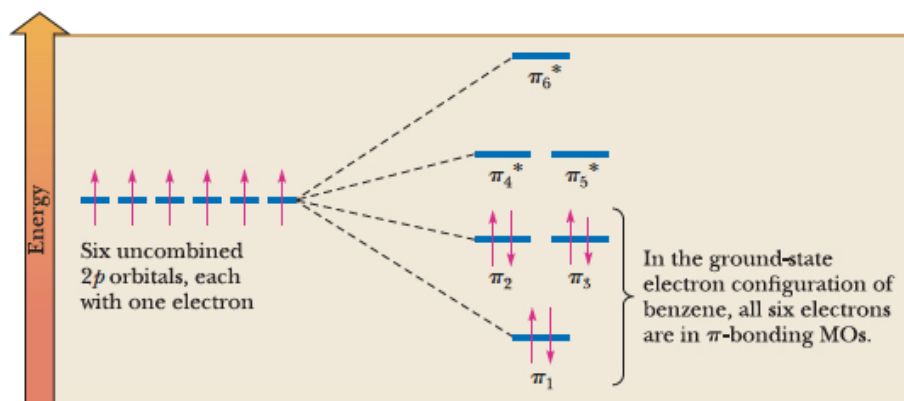

FIGURE 21.2 The molecular orbital representation of the π bonding in benzene.

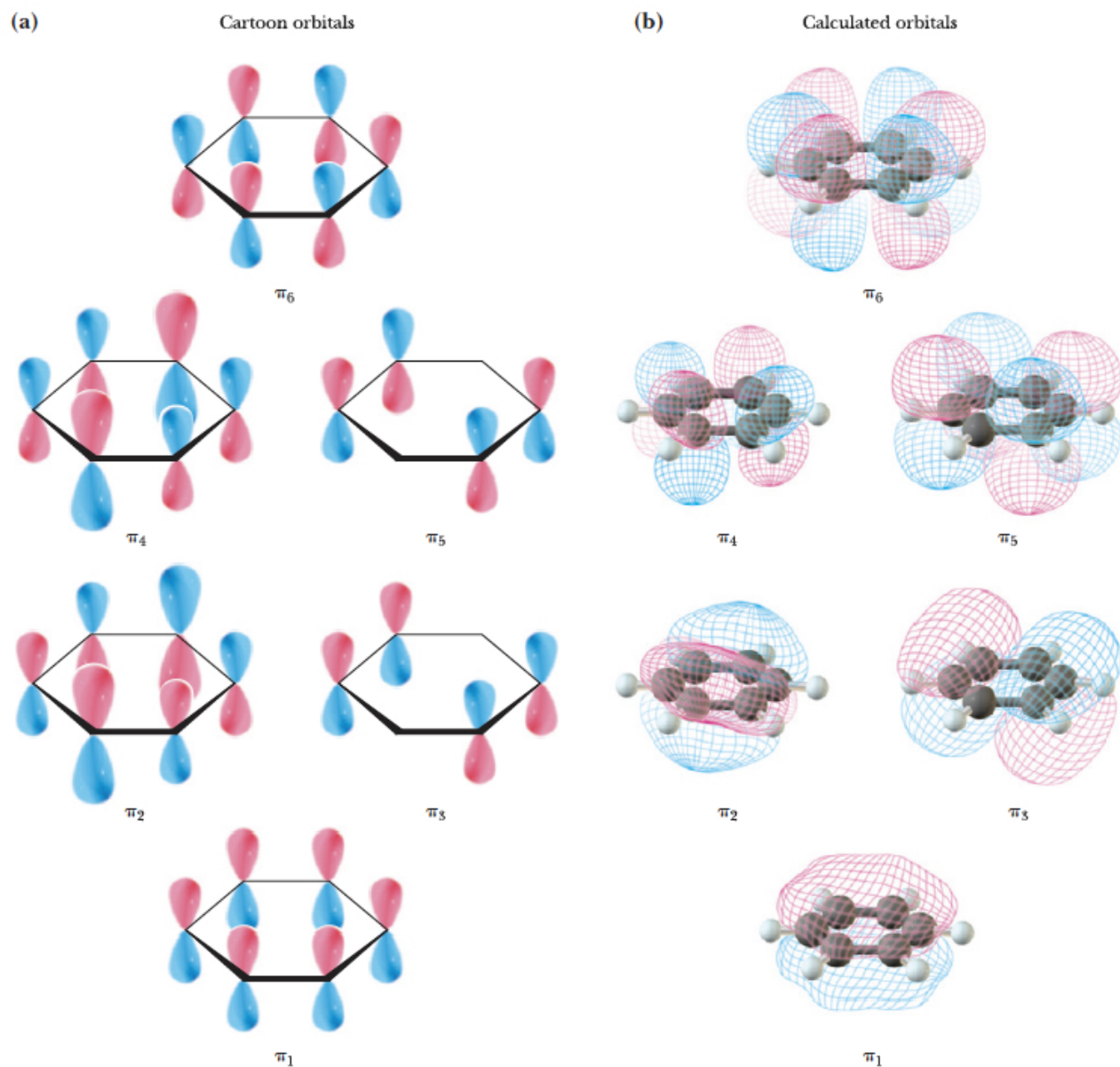
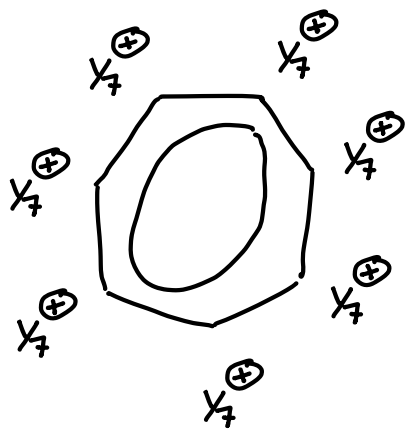
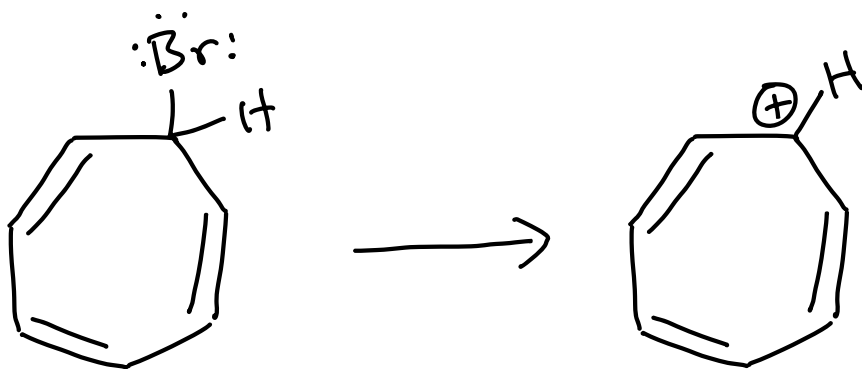

FIGURE 21.3 Orbitals for the π system of benzene. (a) Cartoon representations of the six calculated orbitals that chemists routinely draw. These pictures accentuate the fact that various combinations of parallel $2p$ orbitals lead to the π system of benzene. (b) Calculated orbitals. The three lowest in energy are occupied with electrons (see Figure 21.2). The lowest of these orbitals is the image most chemists use for the π system of benzene: a torus of electron density above and below the ring.

Two Important Consequences of Aromaticity

- 1) Aromaticity stabilizes ions
- 2) Atoms in molecules will be sp^2 if that produces aromaticity

Tropylium Ion



All atoms are equivalent \rightarrow
7 equal contributing structures!

Cyclopentadienyl Anion

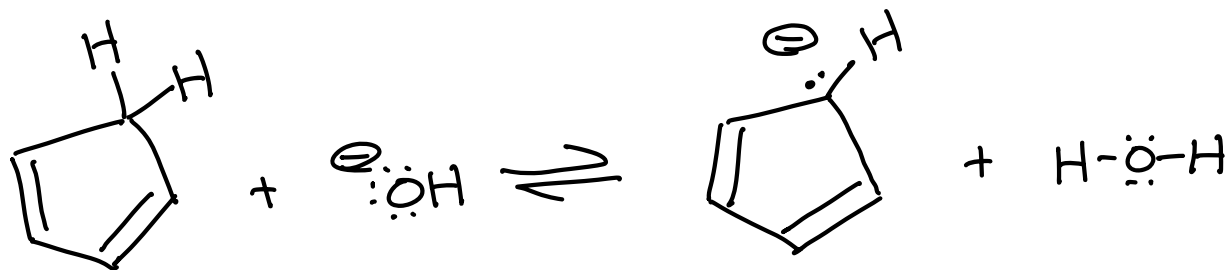

$\text{p}K_{\text{a}} = 16$

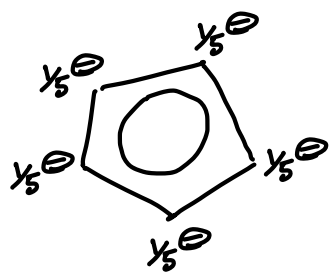

All atoms are
equivalent \rightarrow
5 equal contributing
structures!

Hückel's Aromaticity Criteria

- 1)
- 2)
- 3)
- 4)

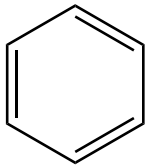

Benzene

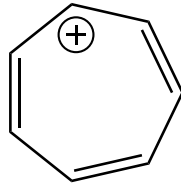

Tropylium Ion

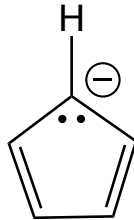

Cyclopentadienyl
anion

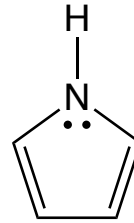

Pyrrole

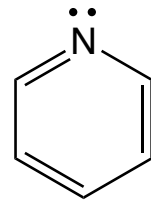

Pyridine

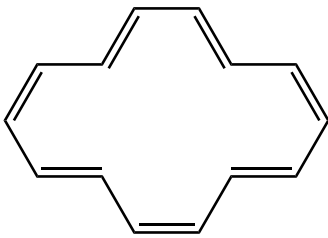

Annulene



Cyclobutadiene

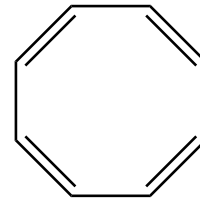

Cyclooctatetraene

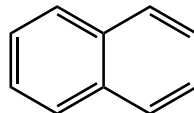

Naphtalene

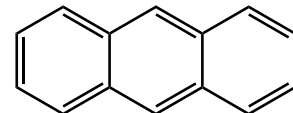

Anthracene

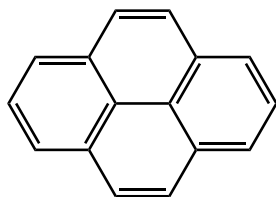

Pyrene

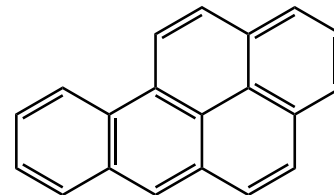

Benzo[α]pyrene

Aromatic resonance stabilization of charged species

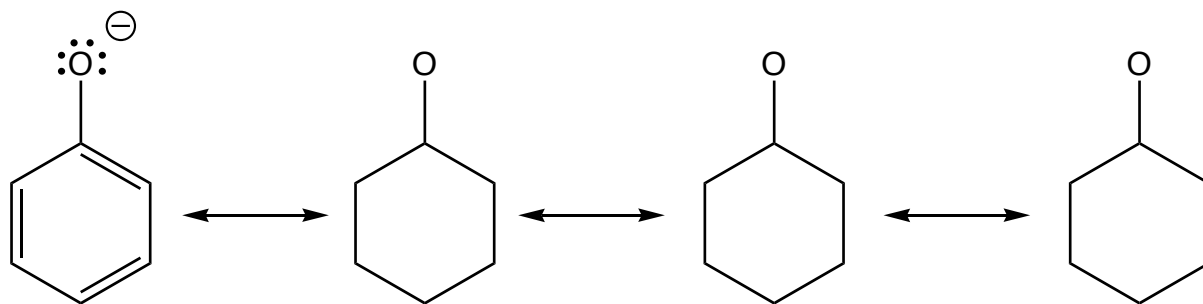

Phenoxide anion

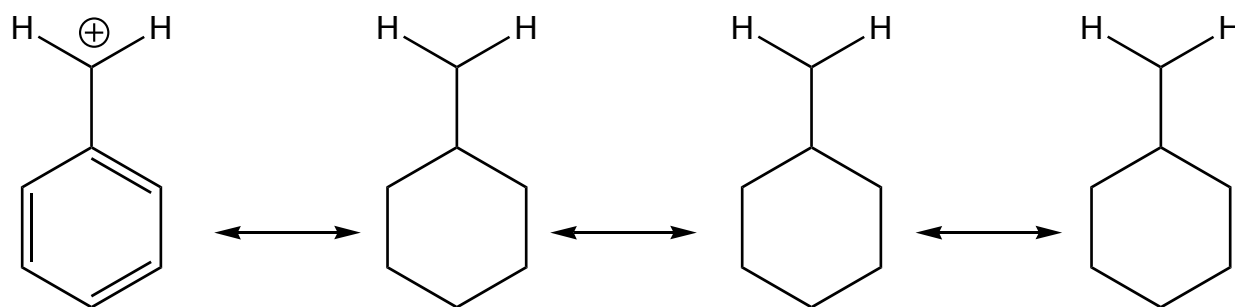

Benzyl cation

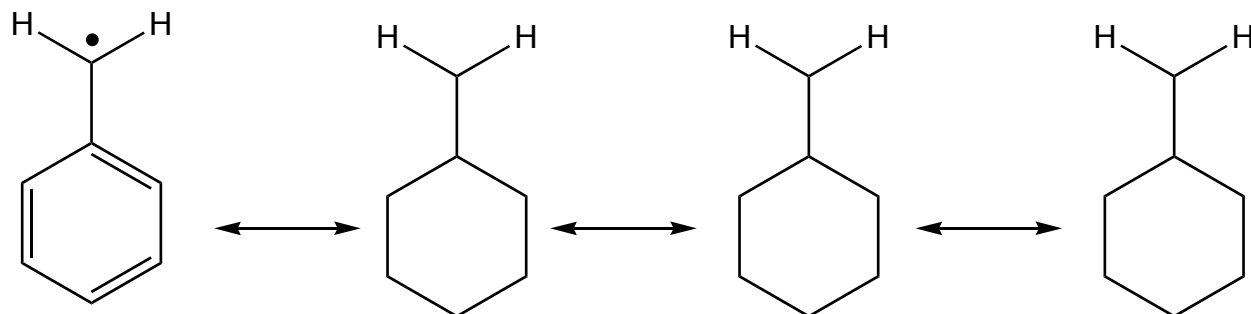

Benzyl radical

Important takeaways from the contributing structures

- 1) Benzene rings stabilize anions, cations and radicals
- 2) Molecules can have electrons on an atom outside the ring delocalized into the π system and the "extra" electrons do not count against the $4n+2$ number of π electrons

Summary \rightarrow

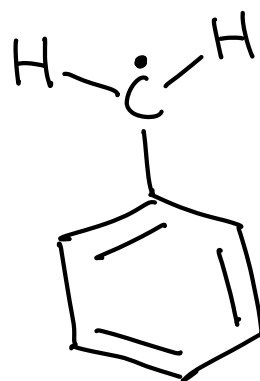
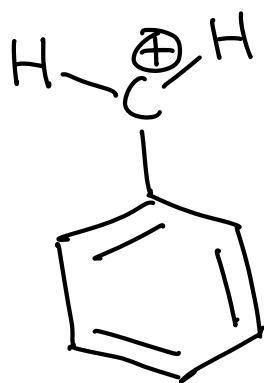
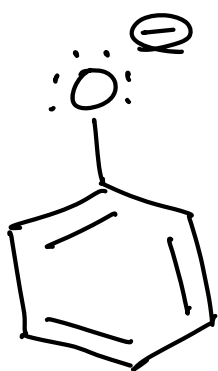

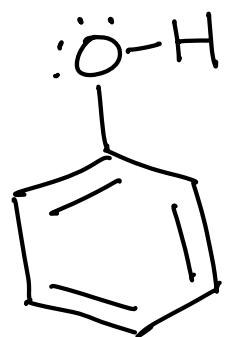

Phenol

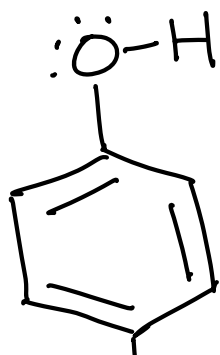

Cl

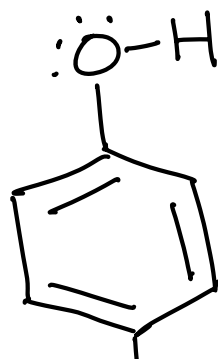

NO₂

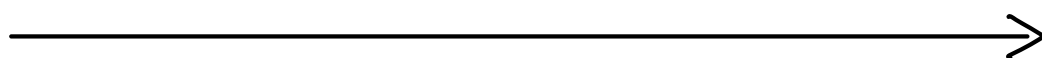

Electron withdrawing groups on the ring the deprotonated anion, making an OH group more (Inductive effect)

Important terms

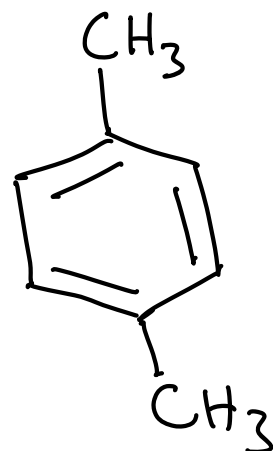
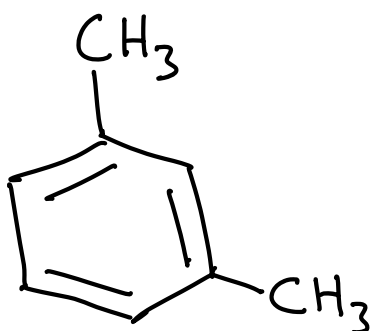
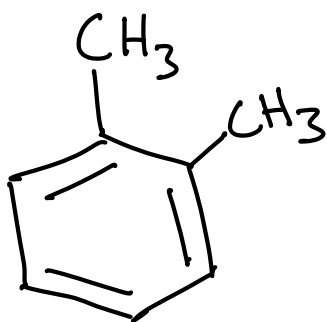

Hückel's Aromaticity Criteria

- 1) All ring atoms are sp^2 (they have a 2p orbital)
- 2) Flat (so the 2p orbitals overlap)
- 3) Monocyclic (Rule 4) only applies to single rings)
- 4) $4n+2$ pi electrons (2,6,10,14....)

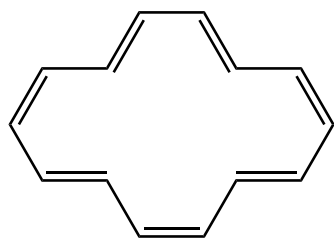
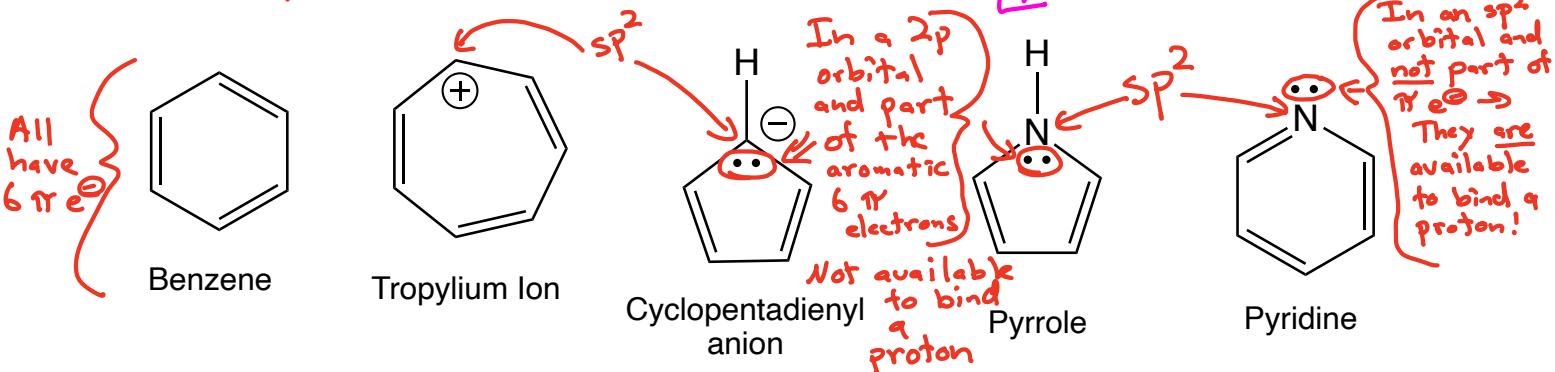

Annulene

14 π electrons

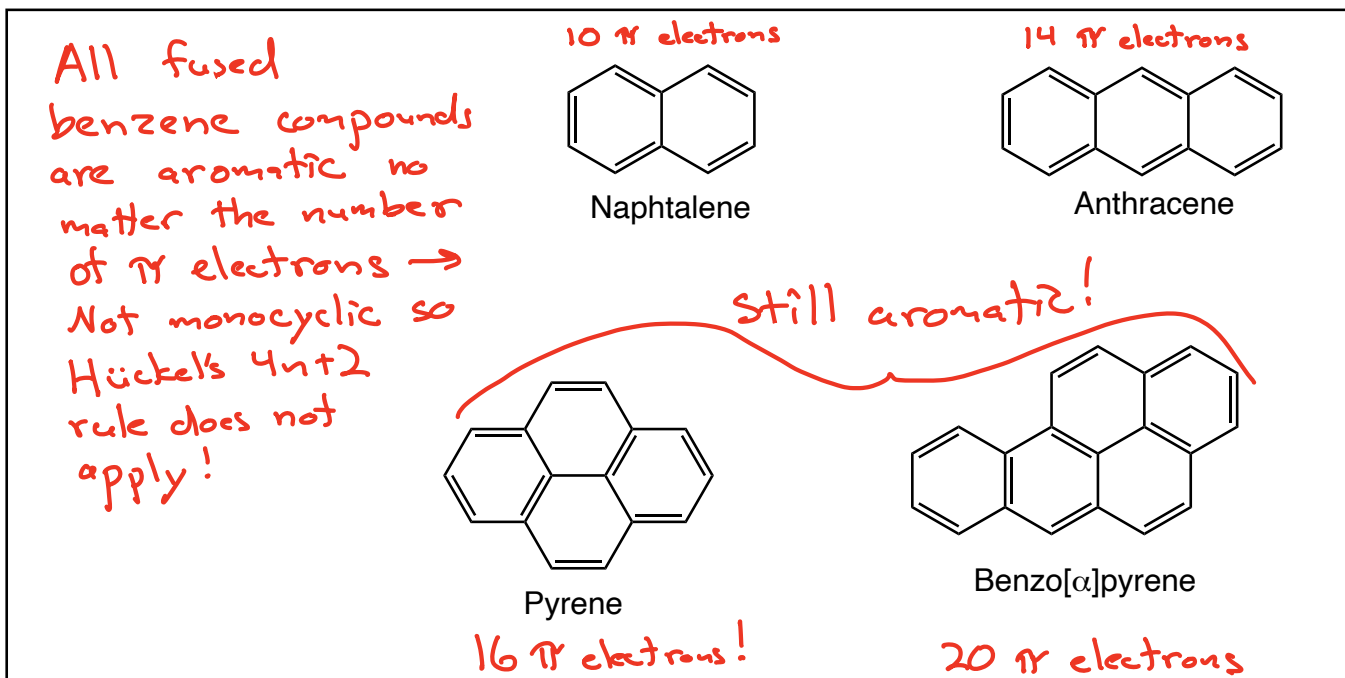
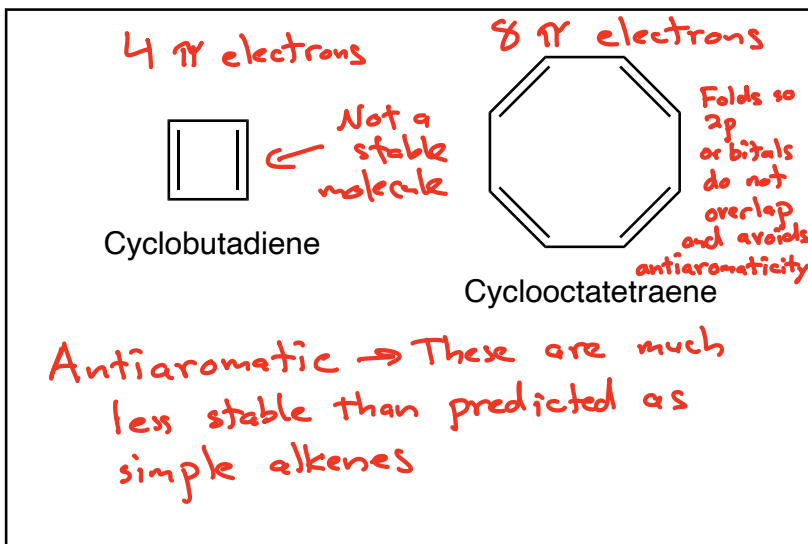

Aromatic resonance stabilization of charged species

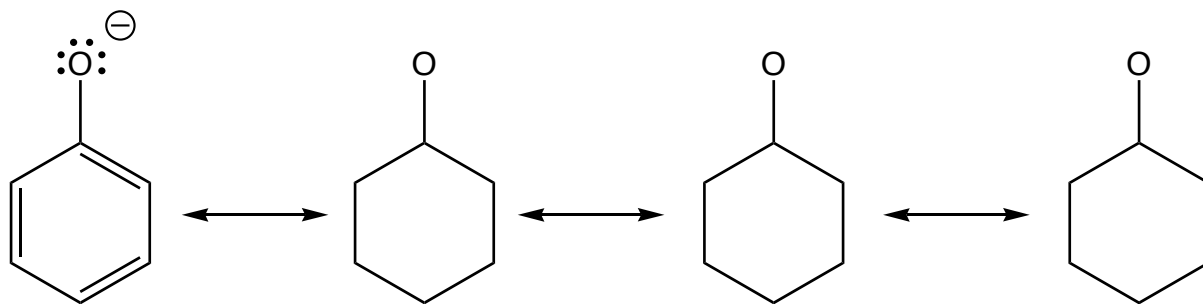

Phenoxide anion

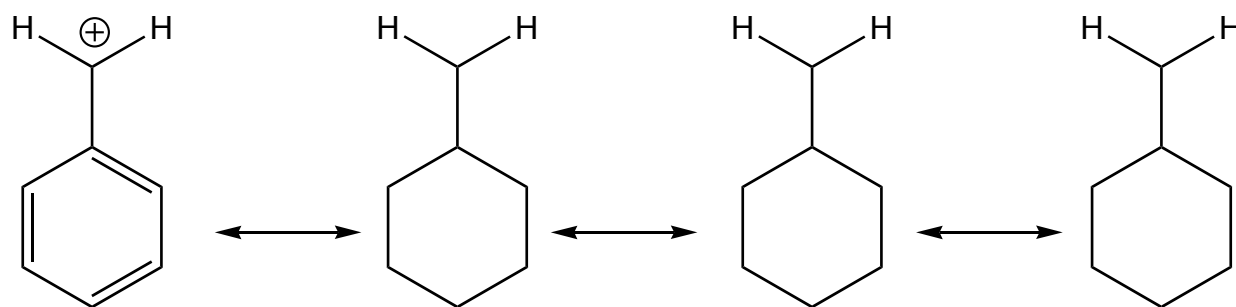

Benzyl cation

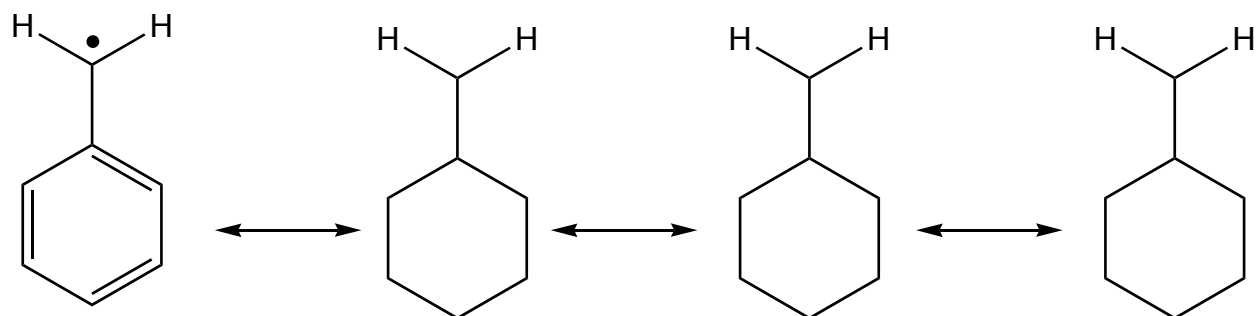

Benzyl radical

Important takeaways from the contributing structures

- 1) Benzene rings stabilize anions, cations and radicals
- 2) Molecules can have electrons on an atom outside the ring delocalized into the π system and the "extra" electrons do not count against the $4n+2$ number of π electrons

Summary \rightarrow

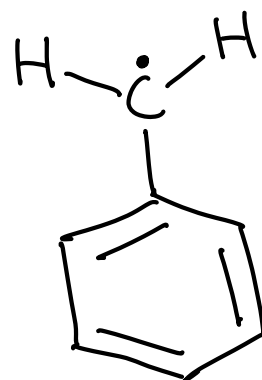
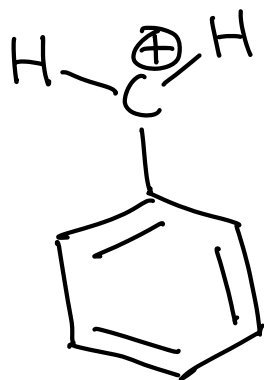
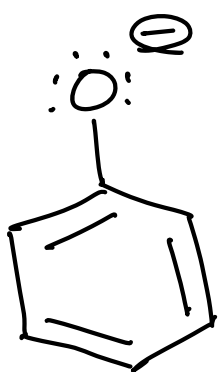

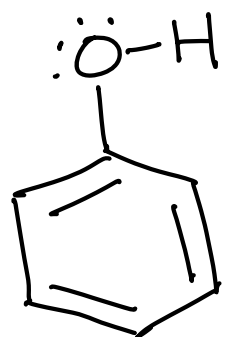

Phenol

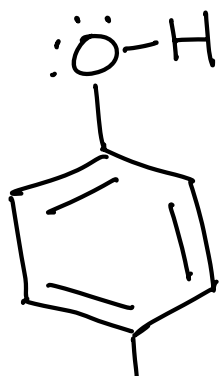

Cl

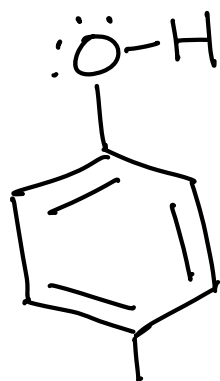

NO₂

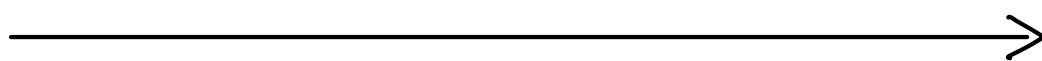

Electron withdrawing groups on the ring the deprotonated anion, making an OH group more (Inductive effect)

Important terms

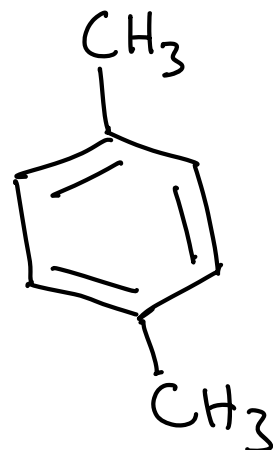
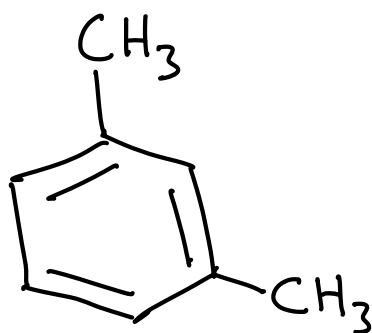
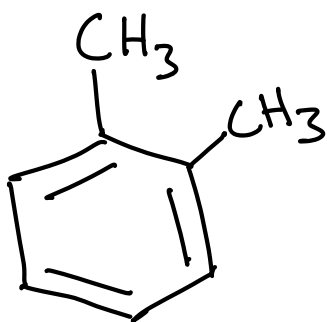

Benzyl vs. Phenyl

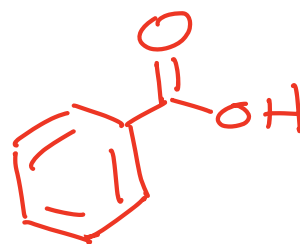
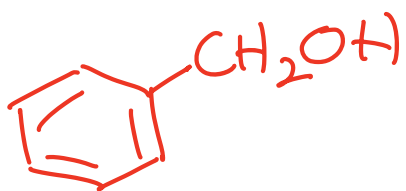
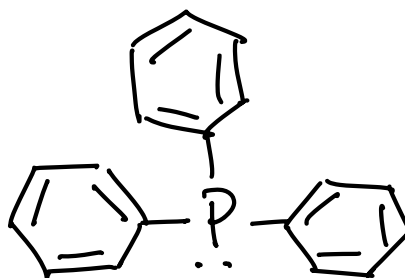
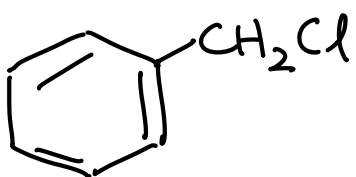

A carbon attached to a benzene ring has special reactivity so it has a special name - the benzyl carbon

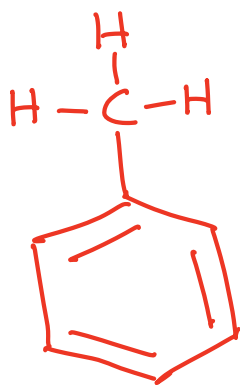

Free radical halogenation

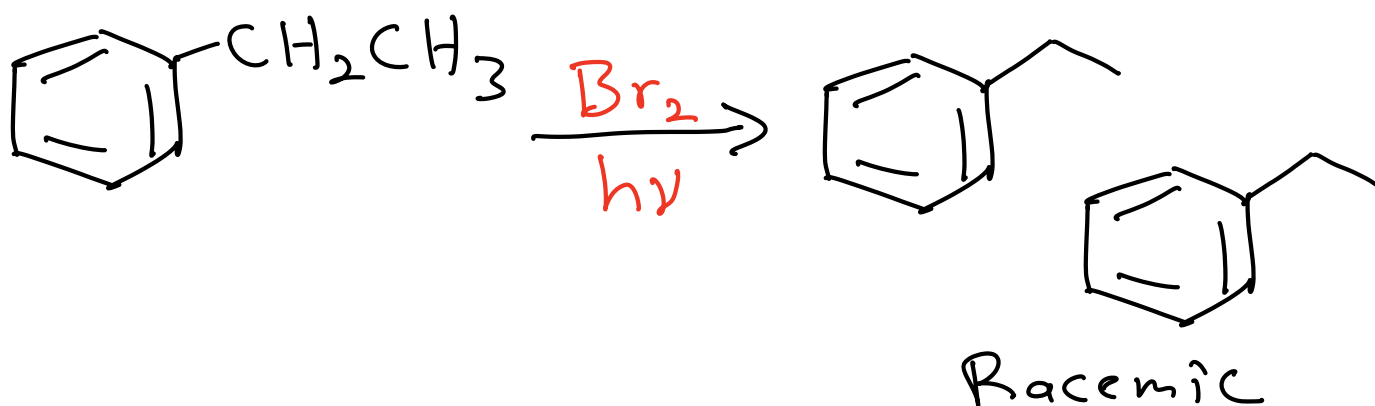

Radical Stability

Methyl $<$ $1^\circ <$ $2^\circ <$ $3^\circ <$ Benzylic Radical

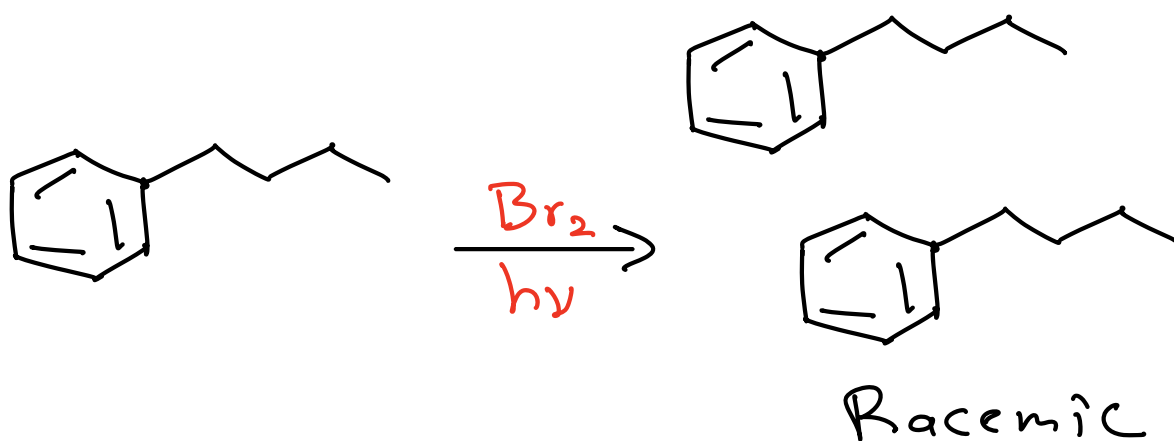

Oxidation

The benzylic carbon is easy to oxidize all the way to a carboxylic acid —

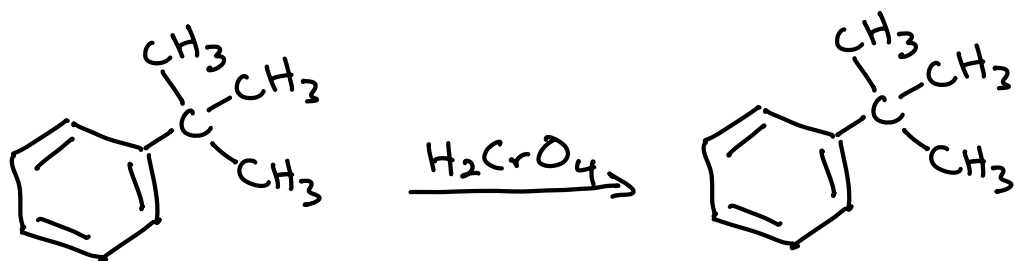
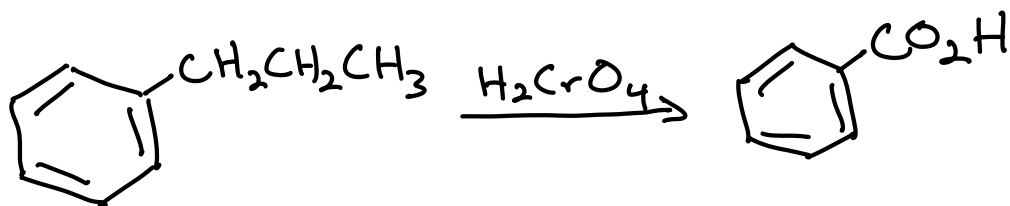
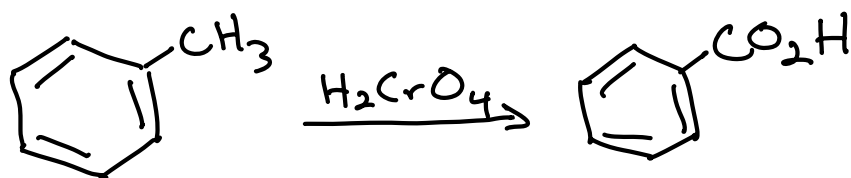

Wicked Strong
Electrophile

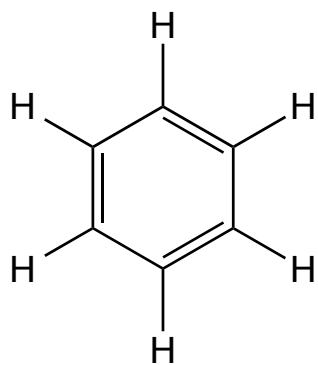

Weak
Nucleophile

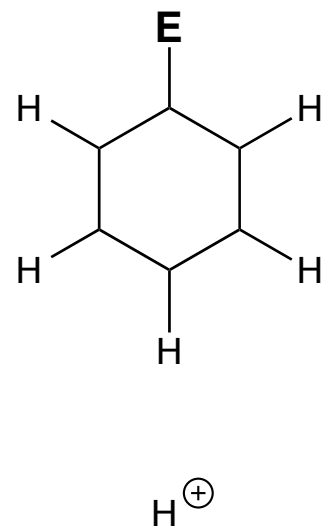
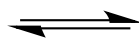
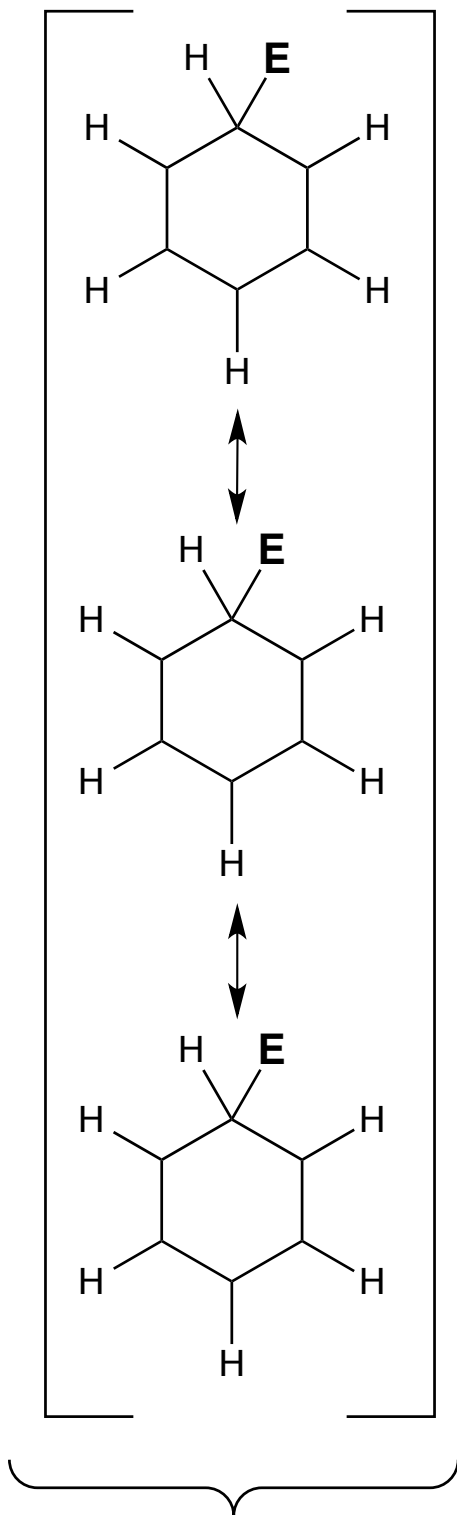
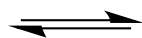

Called the
Arenium Ion

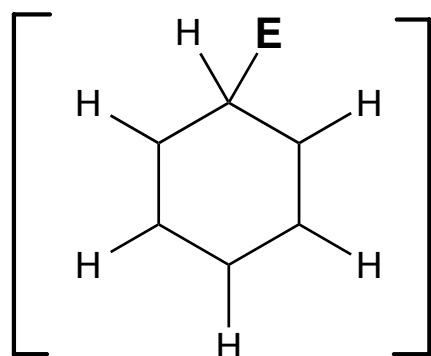

Summary → Wicked strong electrophile reacts with the benzene π electron density to make a resonance delocalized arenium ion intermediate that loses a proton to give a substituted benzene

This reaction is called
"Electrophilic Aromatic Substitution (EAS)"

Reagents

Halogenation X_2, FeX_3

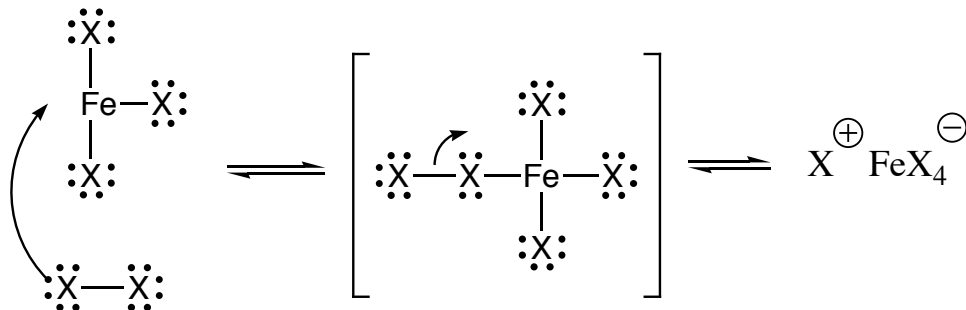

$X = Br, Cl$

Wicked strong
electrophile

E^+

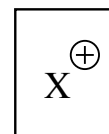

Nitration H_2SO_4/HNO_3

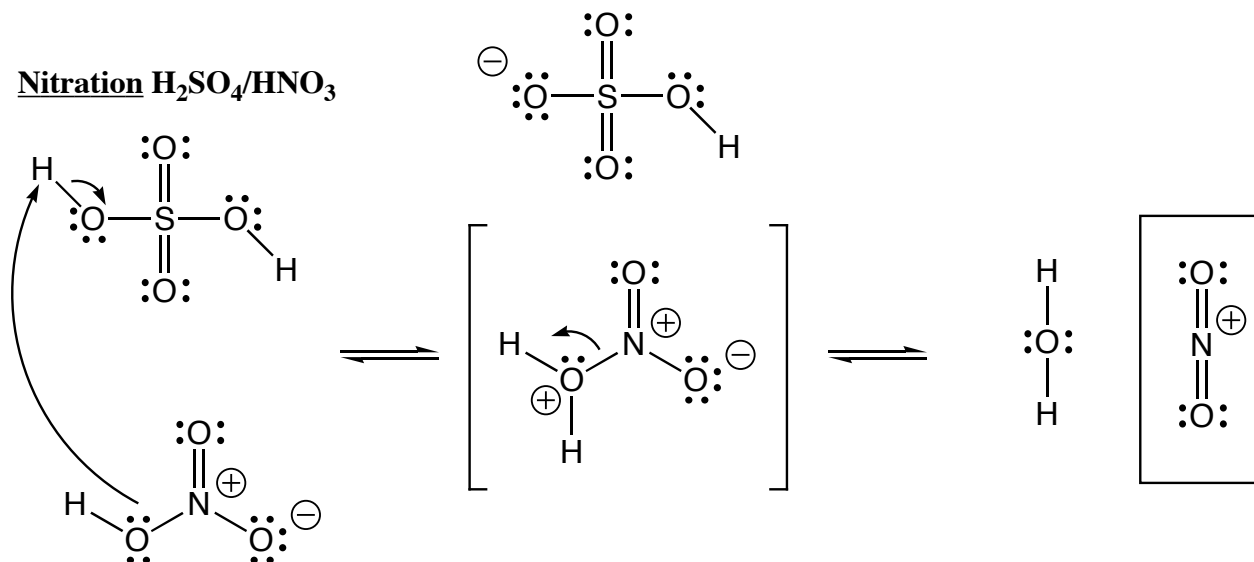

Sulfonation H_2SO_4/SO_3

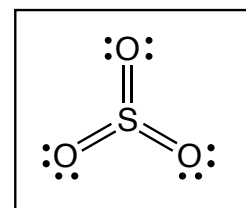
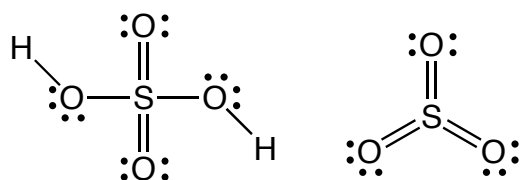

Fuming sulfuric acid
contains both of the
above reagents, the SO_3
is the important one

Reagents

Friedel-Crafts Alkylation $R-X, AlX_3$

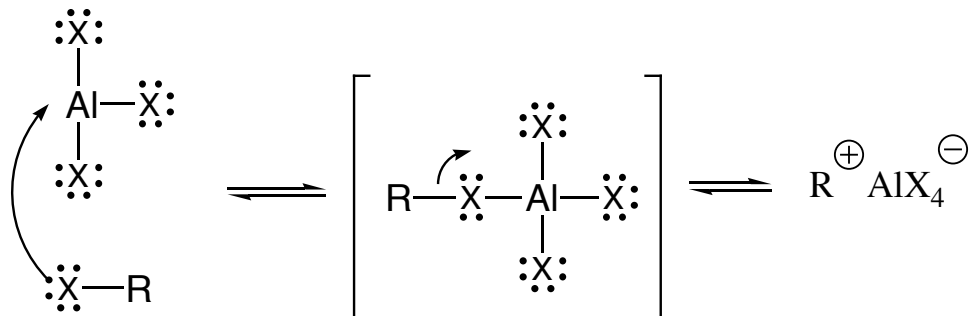

$X = Br, Cl$

Wicked strong electrophile

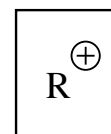

Note this is a carbocation, so it will rearrange if it is a primary or a rearrangement-prone secondary cation

Friedel-Crafts Acylation $RCOCl, AlCl_3$

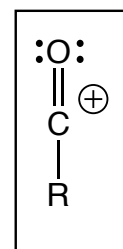
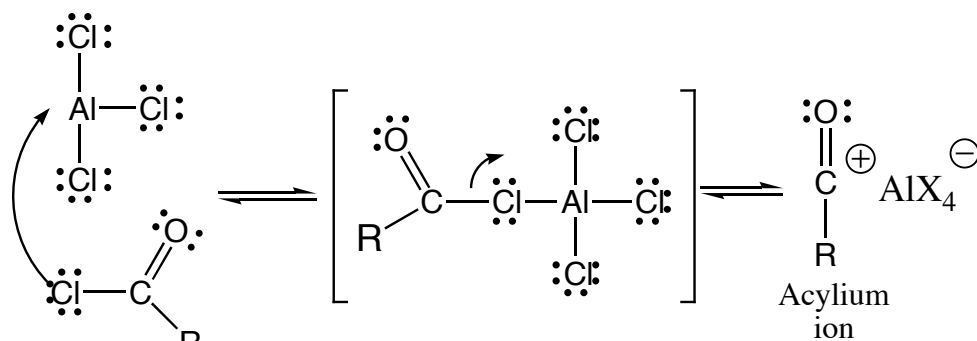

Other notes: 1) It is hard to stop the Friedel-Crafts alkylation after one alkyl group adds (because alkyl groups are "good", that is, activating), but it can be done. 2) Neither Friedel-Crafts reaction works if there is already an electron withdrawing (bad) group on the ring.